

PQ05SZ5/PQ05SZ1 Series

Low Power-Loss Voltage Regulators (Built-in Reverse Voltage Protection Function)

■ Features

- Low power-loss (Dropout voltage: MAX. 0.5V)
- Surface mount type package (Equivalent to SC-63)
- Built-in a function to prevent reverse voltage between input and output
The diode to prevent reverse voltage between input and output is not necessary. (When $V_{O1} \leq 13V$)

■ Applications

- Portable equipment
- Notebook PC

■ Model Line-ups

		5V output	9V Output	12V output
0.5A output	output voltage precision: $\pm 5\%$	PQ05SZ5	PQ09SZ5	PQ12SZ5
	Output voltage precision: $+2.5\%$	PQ05SZ51	PQ09SZ51	PQ12SZ51
1A output	Output voltage precision: $\pm 5\%$	PQ05SZ1	PQ09SZ1	PQ12SZ1
	output voltage precision: $\pm 2.5\%$	PQ05SZ1 1	PQ09SZ1 1	PQ12SZ11

■ Outline Dimensions

(Unit : mm)

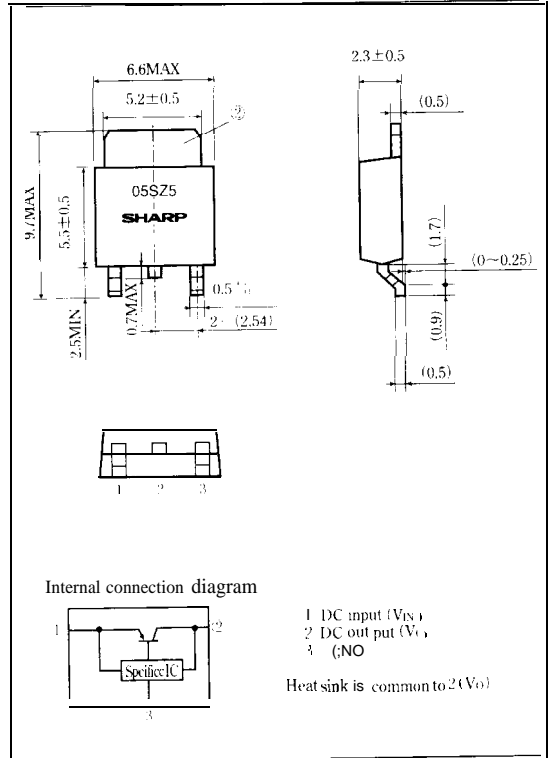

■ Absolute Maximum Ratings

($T_a=25\text{C}$, xx=05,09,12)

(xx: 05,09,12)

Parameter	Symbol	Conditions	Rating		Unit
			PQxxSZ5/51	PQxxSZ1/11	
Input voltage	V_{IN}	*1	24		V
Input-output reverse voltage	V_{O1}	$V_{IN}=0V$	13		v
Output current	I_O		0.5	1.0	A
Power dissipation	P_D	Refer to Fig. 4*2	8		W
Junction temperature	T_j	*	150		$^{\circ}\text{C}$
Operating temperature	T_{opr}		-20 to +80		$^{\circ}\text{C}$
Storage temperature	T_{stg}		-40 to +150		$^{\circ}\text{C}$
Soldering temperature	T_{sol}	For 10s	260		$^{\circ}\text{C}$

*1 All are open except GND and applicable terminals

*2 With infinite heat sink.

* Over heat protection may operate at $T_j \geq 125\text{C}$

Please refer to the chapter Handling Precautions

Electrical Characteristics

(T_J = 25°C, xx = 05, 09, 12)

Parameter		Symbol	Conditions	MIN.	typ.	MAX.	Unit
Output voltage	PQ05SZ1/5	V _O	V _{IN} = 7V	4.75	5.0	5.25	V
	PQ09SZ1/5		V _{IN} = 11V	8.55	9.0	9.45	
	PQ12SZ1/5		V _{IN} = 14V	11.4	12.0	12.6	
	PQ05SZI 1/51		V _{IN} = 7V	4.88	5.0	5.12	
	PQ09SZ11 /51		V _{IN} = 11V	8.78	9.0	9.22	
	PQ12SZ11/51		V _{IN} = 14V	11.7	12.0	12.3	
Load regulation		R _{regL}	*4		0.2	2.0	%
Line regulation		R _{regI}	I _O = 5mA, *5		0.1	2.5	%
Temperature coefficient of output voltage		T _c (V)	I _O = 5mA, T _J = 0 to 125°C, *6		±0.01	—	%/°C
Ripple rejection		RR	Refer to Fig. 2	45	60	—	dB
Dropout voltage	PQxxSZ1/11	V _{I-O}	*7	I _O = 0.5A	0.2	0.5	V
	PQxxSZ5/51			I _O = 0.3A			
Quiescent current		I _q	I _O = 0A, *8	4.0	10.0	—	mA

*3 PQxxSZ1/11 Series: I_O = 0.5A

PQxxSZ5/51 Series: I_O = 0.3A

*4 PQ05SZ1/11: V_{IN} = 7V, I_O = 5mA to 1.0A PQ05SZ5/51: V_{IN} = 7V, I_O = 5mA to 0.5A

PQ09SZ1/11: V_{IN} = 11V, I_O = 5mA to 1.0A PQ09SZ5/51: V_{IN} = 11V, I_O = 5mA to 0.5A

PQ12SZ1/11: V_{IN} = 14V, I_O = 5mA to 1.0A PQ12SZ5/51: V_{IN} = 14V, I_O = 5mA to 0.5A

*5 PQ05SZ1/11/5/51: V_{IN} = 6 to 16V

PQ09SZ1/11/5/51: V_{IN} = 10 to 20V

PQ12SZ1/11/5/51: V_{IN} = 13 to 23V

*6 PQ05SZ1/11/5/51: V_{IN} = 7V

PQ09SZ1/11/5/51: V_{IN} = 11V

PQ12SZ1/11/5/51: V_{IN} = 14V

*7 Input voltage shall be the value when output voltage is 95% in comparison with the initial value

Fig.1 Test Circuit

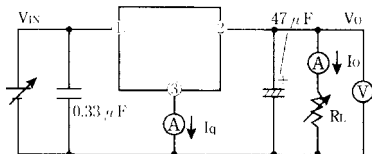
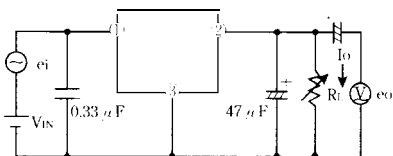

Fig.2 Test Circuit of Ripple Rejection



f = 120Hz (sinewave)

e_i = 0.5V_{rms}

V_{IN} = 7V (PQ05SZ1/1 q/5/51)

V_{IN} = 11V (PQ09SZ1/11/5/51)

V_{IN} = 14V (PQ12SZ1/11/5/51)

I_O = 0.3A

RR = 20log(e_i/e_o)

Fig.3 Overcurrent Protection Characteristics (Typical Value)

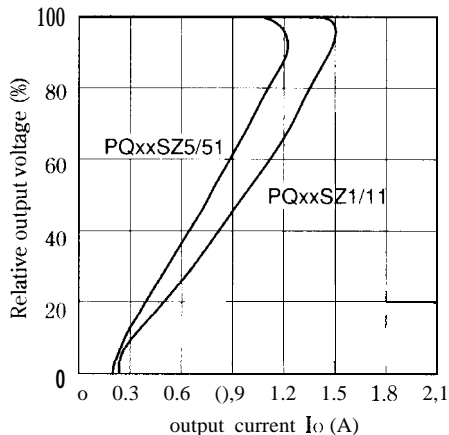
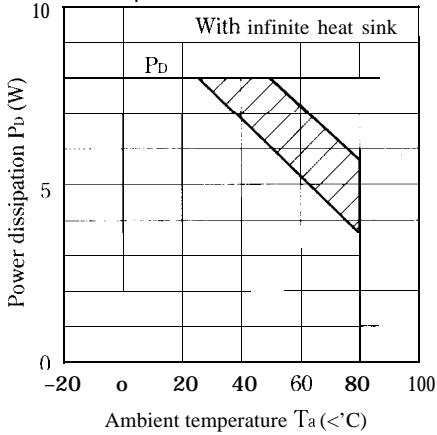

Fig. 4 Power Dissipation vs. Ambient Temperature



Note) oblique line portion : Overheat protection may operate in this area.

Fig. 6 Output Voltage Deviation vs. Junction Temperature (PQ09SZ1/PQ09SZ11/PQ09SZ5/PQ09SZ51)

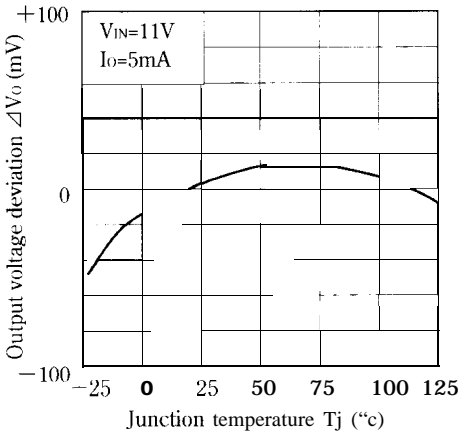

Fig. 8 Output Voltage vs. Input Voltage (PQ05SZI/PQ05SZ11)

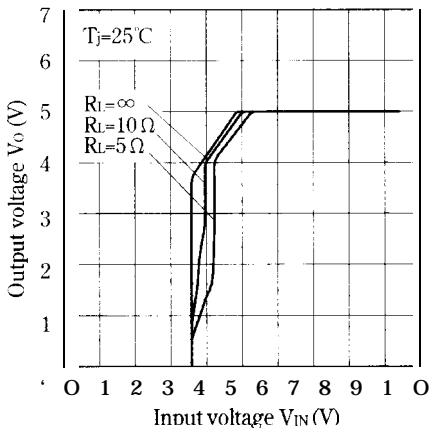

Fig. 5 Output Voltage Deviation vs. Junction Temperature (PQ05SZ1/PQ05SZ11/PQ05SZ5/PQ05SZ51)

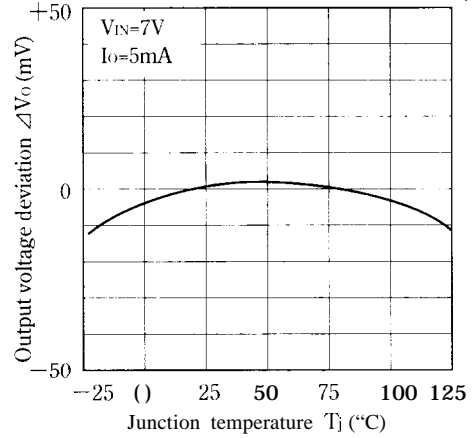

Fig. 7 Output Voltage Deviation vs. Junction Temperature (PQ12SZ1/PQ12SZ11/PQ12SZ5/PQ12SZ51)

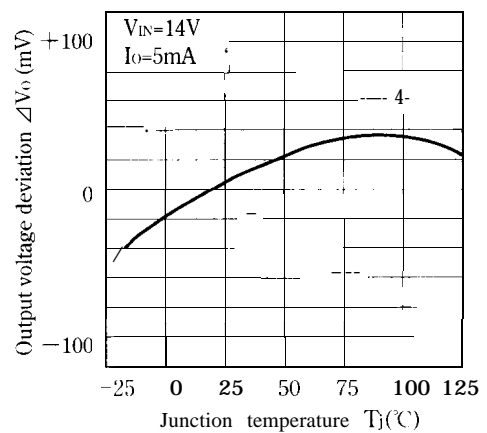

Fig. 9 Output Voltage vs. Input Voltage (PQo5sz5/PQo5sz51)

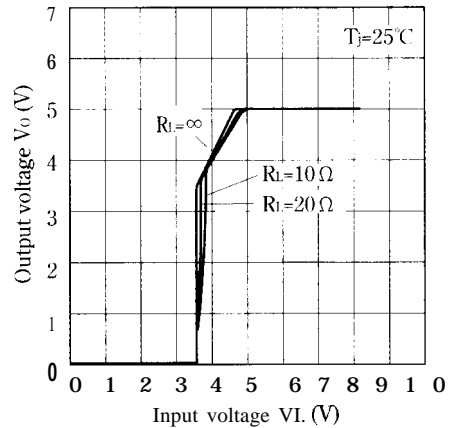

Fig.10 Output Voltage vs. Input Voltage (PQ09SZ1/pQ09SZ11)

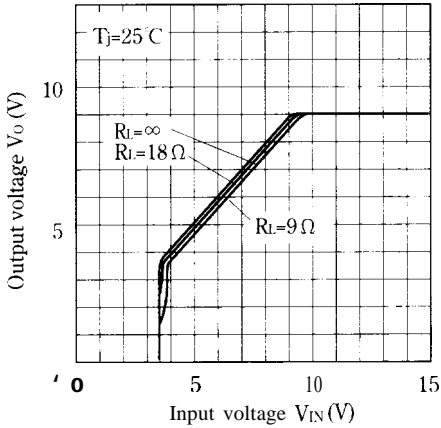

Fig.11 Output Voltage vs. Input Voltage (PQ09SZ5/PQ09SZ51)

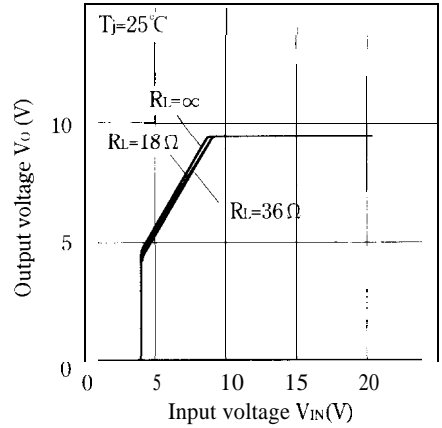

Fig.12 Output Voltage vs. Input Voltage (PQ12SZ1/PQ12SZ11)

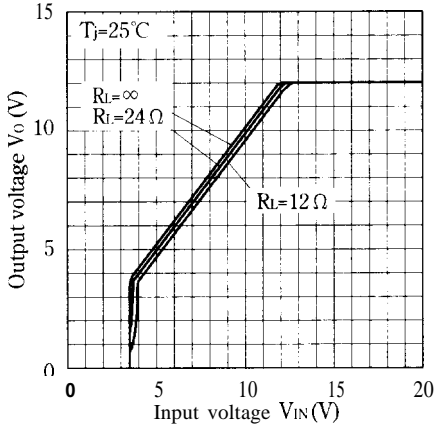

Fig.13 Output Voltage vs. Input Voltage (PQ12SZ5/PQ12SZ51)

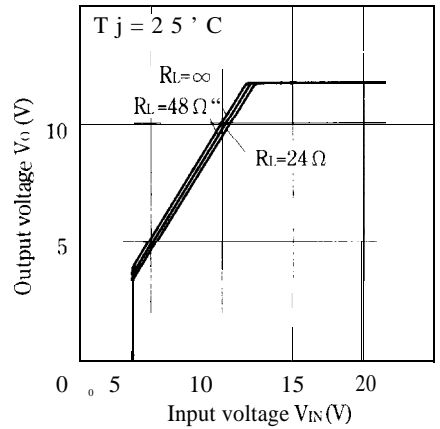

Fig.14-a Dropout Voltage vs. Junction Temperature (PQ05SZ5/51 Series)

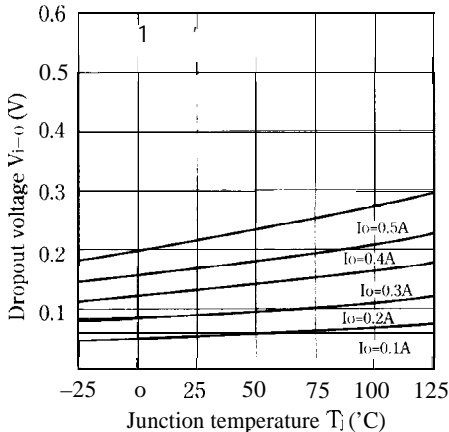

Fig.14-b Dropout Voltage vs. Junction Temperature (PQ05SZ1/11 Series)

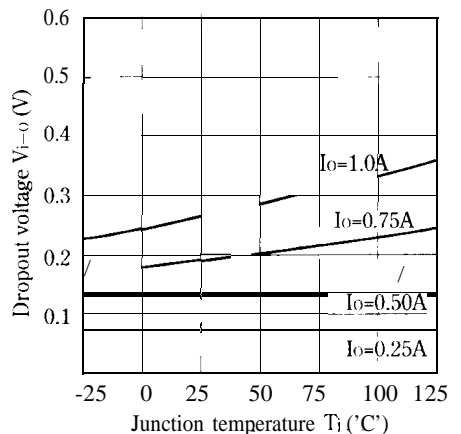

Fig.15 Circuit Operating Current vs. Input Voltage (PQ05SZ1/PQ05SZ11)

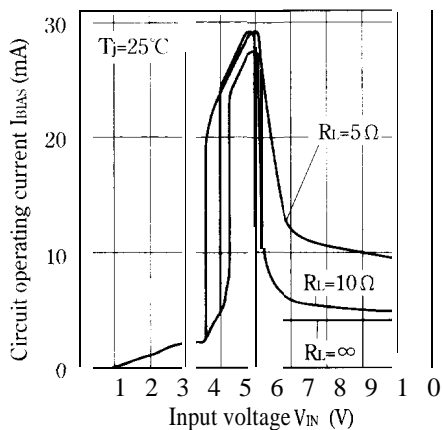

Fig.16 Circuit Operating Current vs. Input Voltage (PQ05SZ5/PQ05SZ51)

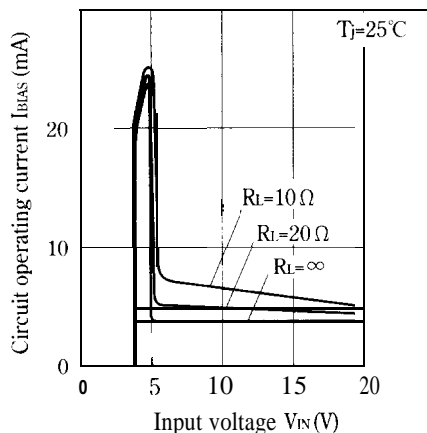

Fig.17 Circuit Operating Current vs. Input Voltage (PQ09SZ1/PQ09SZ11)

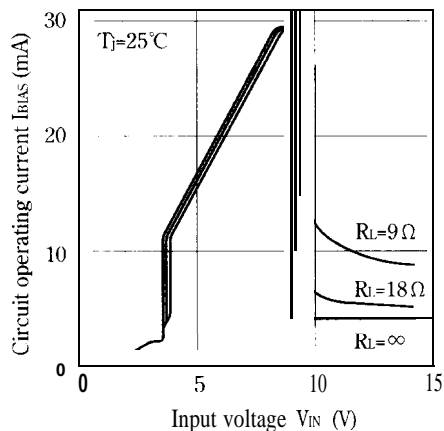

Fig.18 Circuit Operating Current vs. Input Voltage (PQ09SZ5/PQ09SZ51)

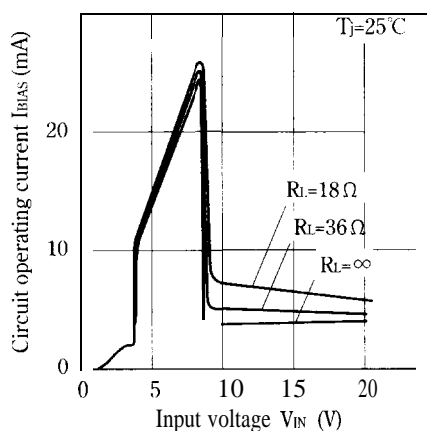

Fig.19 Circuit Operating Current vs. input Voltage (PQ12SZ1/PQ12SZ11)

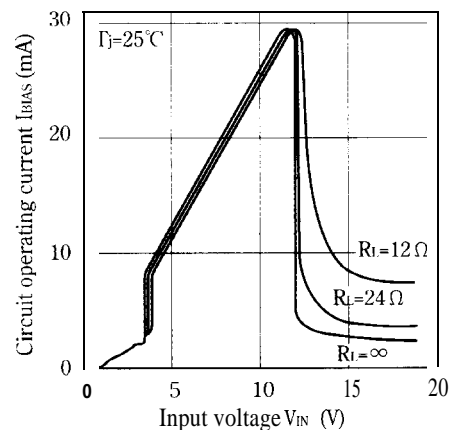

Fig.20 Circuit Operating Current vs. input Voltage (PQ12SZ5/PQ12SZ51)

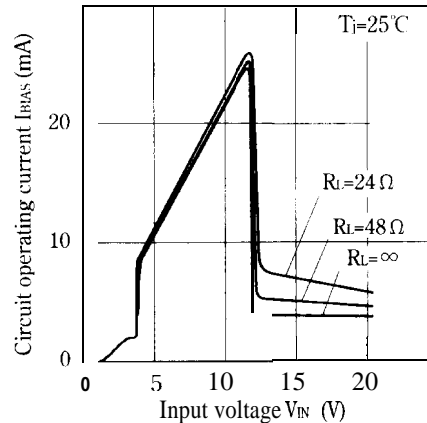

Fig.21 Quiescent Current vs. Junction Temperature

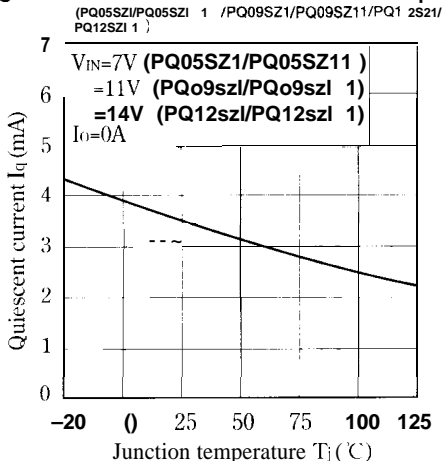

Fig.22 Ripple Rejection vs. Input Ripple Frequency

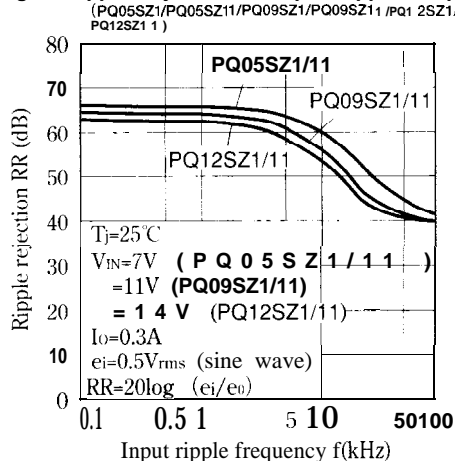

Fig.23 Ripple Rejection vs. Input Ripple Frequency

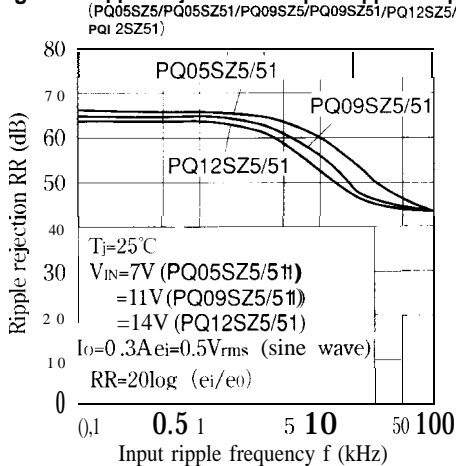

Fig.24 Ripple Rejection vs. Output Current

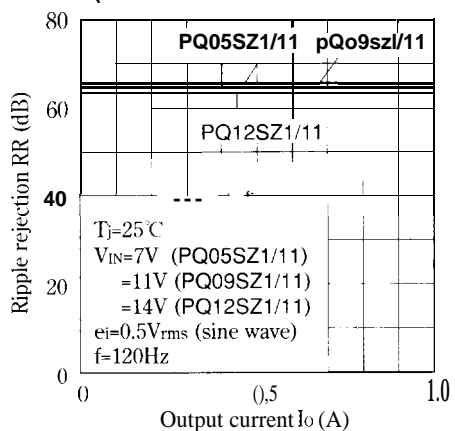

Fig.25 Ripple Rejection vs. Output Current

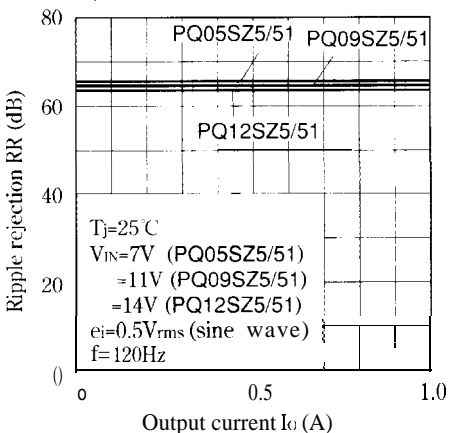

Fig.26 Input-Output Reverse Current vs. Input-Output Reverse Voltage

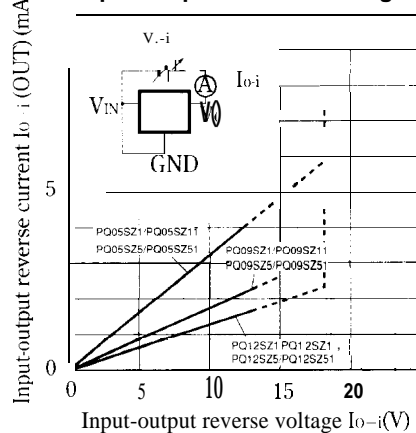

Fig.27 Power Dissipation vs. Ambient Temperature (Typical Value)

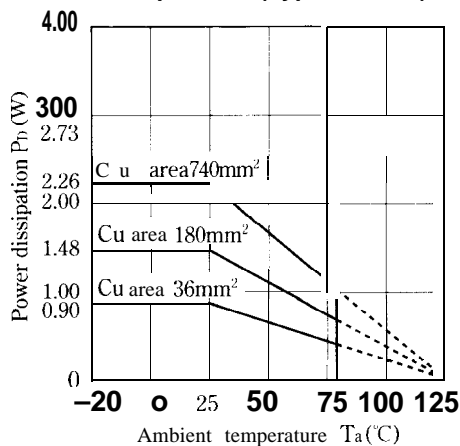
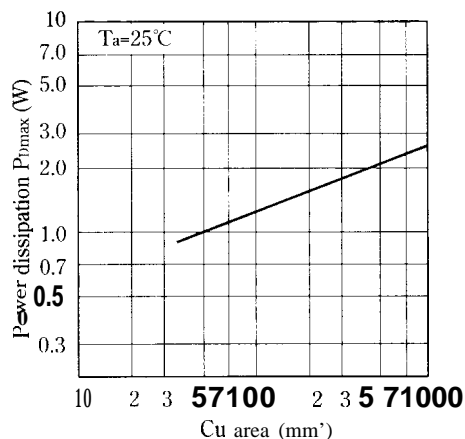
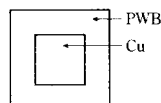

Fig.28 Power Dissipation vs. Cu Area



PWB



Material : Glass-cloth epoxyresin
 Size : 50X5(1X1) 6mm²
 Cu thickness : 35 μ m

Model Line-ups for Tape-packaged Products

Output current	Sleeve-packaged products		Tape-packaged products	
	Standard type	High-precision output type	Standard type	High-precision output type
0.5A output	PQ05SZ5 Series	PQ05SZ51 Series	PQ05SZ5T Series	PQ05SZ5U Series
1.0A output	PQ05SZ1 Series	PQ05SZ11 Series	PQ05SZ1 T Series	PQ05SZ1 U Series